



# ST. ANNE'S COLLEGE OF ENGINEERING AND TECHNOLOGY

## DEPARTMENT OF MECHANICAL ENGINEERING

### ME8593 – DESIGN OF MACHINE ELEMENT

#### QUESTION BANK

#### **Unit -1: STEADY STRESSES AND VARIABLE STRESSES IN MACHINE MEMBERS**

##### **PART-A**

1. What are the steps in machine design process?
2. How will you classify machined design and explain it?
3. Enumerate the most commonly used engineering materials and state at least one important property and one application of each
4. Why are metals in their pure form unsuitable for industrial use?
5. Define 'mechanical property' of an engineering material. State any six mechanical properties give their definitions and one example of the material possessing the properties.
6. What are fits and tolerances? How are they designated
7. What do you understand by the nominal size and basic size?
8. Write short notes on the following:
  - a. Interchangeability
  - b. Tolerance
  - c. Allowance and
  - d. Fits
9. What is the difference in the type of assembly generally used in running fits and interference fits?
10. Define unilateral and bilateral tolerance.
11. What is meant by 'hole basis system' and 'shaft basic system'? Which one is preferred and why?
12. Discuss the Indian standard system of limits and fits.
13. What are the commonly used fits according to Indian standards?
14. What do you understand by preferred numbers?

15. Write Soderberg equation for a machine component subjected to
  - a. Combination of mean and variable torques
  - b. Combination of mean and variable bending moments.
16. How is the working stress calculated from the yield stress of a material?
17. What is meant by stress concentration? How do you take it into consideration in case of a component subjected to dynamic loading?
18. For Ductile material, which of the strength is considered for designing a
  - a. Component subjected to static loading
  - b. Component subjected to fatigue loading
19. What is Gerber Theory?
20. What is the force required to punch a hole of diameter 'd' in a metal of thickness 't' having ultimate shear strength as ' $\tau_u$ '?

**PART-B**

1. The frame of a punch press is shown in Fig. 5.9. Find the stresses at the inner and outer surface at section X-X of the frame, if  $W = 5000$  N.

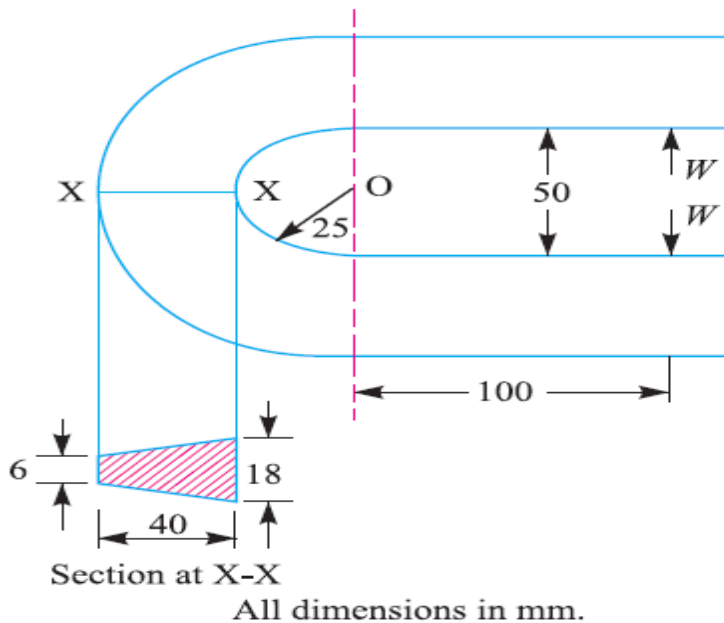

2. The load on a bolt consists of an axial pull of 10kN together with a transverse shear force of 5Kn. Find the diameter of bolt required according to
  1. Maximum principal stress theory; 2. Maximum shear stress theory; 3. Maximum principal strain theory; 4. Maximum strain energy theory and 5. Maximum distortion energy theory.

3. A bar of circular cross section is subjected to alternating tensile forces varying from a minimum of 200kN to a maximum of 500kN. It is to be manufactured of material with an ultimate tensile strength of 900Mpa and an endurance limit of 700Mpa. Determine the diameter of bar using safety factors of 3.5 related to ultimate tensile strength and 4 related to endurance limit and stress concentration factor of 1.65 for a fatigue load. Use Goodman straight line as basis for design.

4. An overhang crank with pin and shaft is shown in Fig. 5.18. A tangential load of 15 kN acts on the crank pin. Determine the maximum principal stress and the maximum shear stress at the centre of the crankshaft bearing.

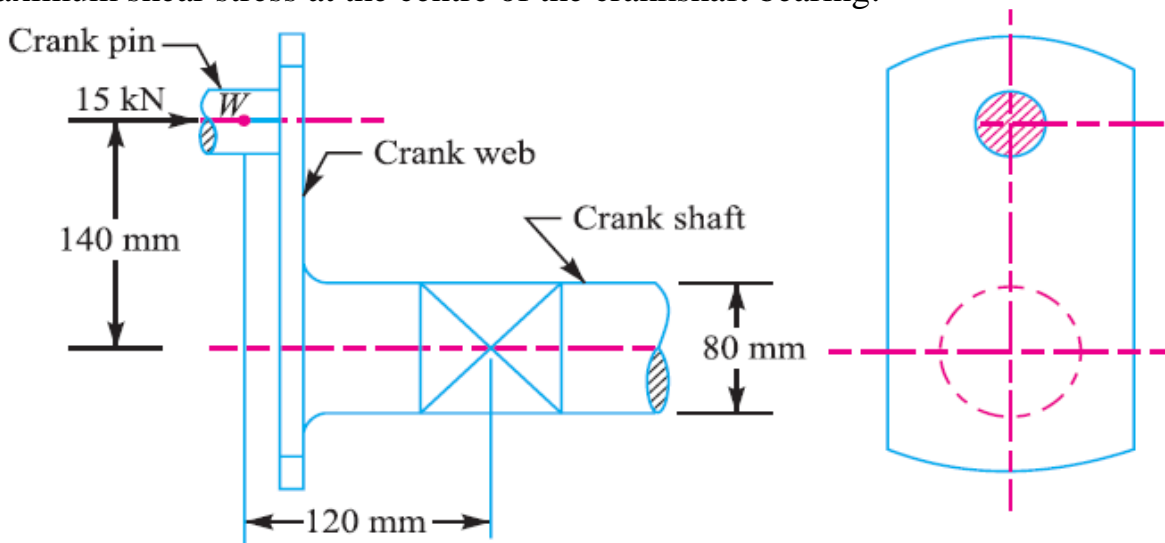

5. A mild steel bracket as shown in fig. (1) is subjected to a pull of 6000N acting at 45° to its horizontal axis. The bracket has a rectangular section whose depth is twice the thickness. Find the cross sectional dimensions of the bracket, if the permissible stress in the material of the bracket is limited to 60 MPa.

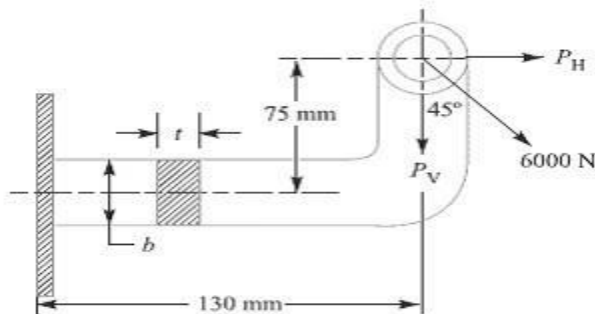

6. Find the maximum stress induced in the following cases taking stress concentration into account:

1. A rectangular plate 60 mm  $\times$  10 mm with a hole 12 diameter as shown in Fig. (a) and subjected to a tensile load of 12 kN.
2. A stepped shaft as shown in Fig. (b) and carrying a tensile load of 12 kN.

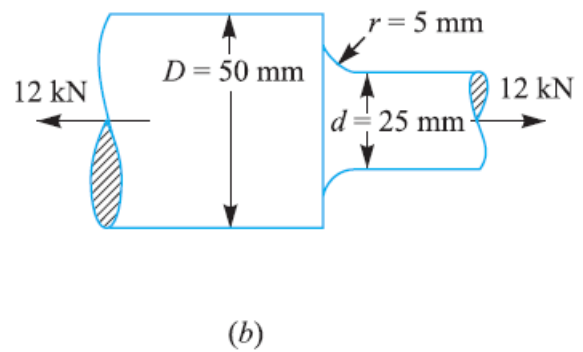
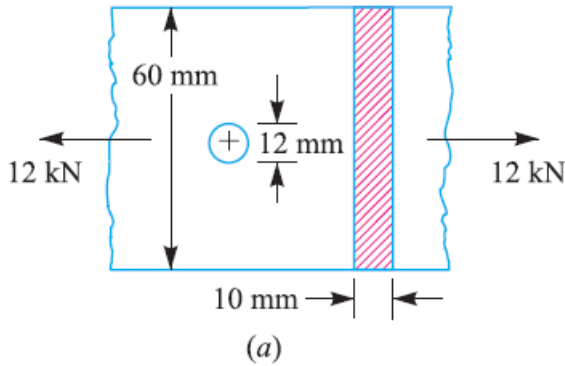

7. A leaf spring in an automobile is subjected to cyclic stresses. The average stress = 150 MPa; variable stress = 500 MPa; ultimate stress = 630 MPa; yield point stress = 350 MPa and endurance limit = 150 MPa. Estimate, under what factor of safety the spring is working, by Goodman and Soderberg formulae.
8. A steel connecting rod is subjected to a completely reversed axial load of 160 kN. Suggest the suitable diameter of the rod using a factor of safety 2. The ultimate tensile strength of the material is 1100 MPa, and yield strength 930 MPa. Neglect column action and the effect of stress concentration.

### PART-C

1. The crank hook carries a load of 20 kN as shown in FIG.(2). This section at X-X is rectangular whose horizontal side is 100 mm. Find the stresses in the inner and outer fibers at the given section

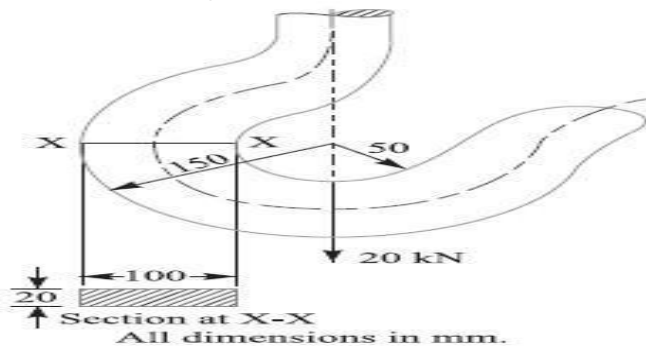

2. A C-clamp as shown in Fig. Carries a load  $P = 25$  kN. The cross-section of the clamp at X-X is rectangular having width equal to twice thickness. Assuming that the clamp is made of steel casting with an allowable stress of 100 MPa, find its dimensions.

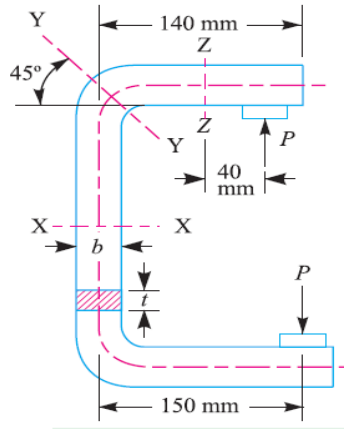

3. A pulley is keyed to a shaft midway between two anti-friction bearings. The bending moment at the pulley varies from  $-170$  N-m to  $510$  N-m and the torsional moment in the shaft varies from  $55$  N-m to  $165$  N-m. The frequency of the variation of the loads is the same as the shaft speed. The shaft is made of cold drawn steel having an ultimate strength of  $540$  MPa and yield strength of  $400$  MPa. Determine the required diameter for an indefinite life. The stress concentration factor for the keyway in bending and torsion may be taken as  $1.6$  and  $1.3$  respectively. The factor of safety is  $1.5$ . Take size factor =  $0.85$  and surface finish factor =  $0.88$ .

\*\*\*\*\*

## UNIT-II SHAFTS AND COUPLINGS PART-A

1. Distinguish clearly, giving examples between pin, axle and shaft.
2. How the shafts are formed?
3. Discuss the various types of shafts and the standard sizes of transmissions shafts.
4. What types of stresses are induced in shafts?
5. How the shaft is designed when it is subjected to twisting moment only?
6. Define equivalent twisting moment and equivalent bending moment. State when these two terms are used in design of shafts.
7. When the shaft is subjected to fluctuating loads, what will be the equivalent twisting moment and equivalent bending moment?
8. What do you understand by torsional rigidity and lateral rigidity?
9. A hollow shaft has greater strength and stiffness than solid shaft of equal weight. Explain.

10. Under what circumstances are hollow shafts preferred over solid shafts? Give any two examples where hollow shafts are used. How they are generally manufactured?
11. What is a key? State its function.
12. How are the keys classified? Draw neat sketches of different types of keys and state their applications.
13. What are the considerations in the design of dimensions of formed and parallel key having rectangular cross-section?
14. Write short note on the splined shaft covering the points of application, different types and method of manufacture.
15. What is the effect of keyway cut into the shaft?
16. Discuss the function of a coupling. Give at least three practical applications.
17. How does the working of a clamp coupling differ from that of a muff coupling? Explain.
18. Sketch a protective type flange coupling and indicate there on its leading dimensions for shaft size of ' $d$ '.
19. What are flexible couplings and what are their applications? Illustrate your answer with suitable examples and sketches.
20. Why are two universal joints often used when there is angular misalignment between two shafts?

#### **PART-B**

1. A hollow steel shaft transmits 600 kW at 500 r.p.m. The maximum shear stress is 62.4 MPa. Find the outside and inside diameter of the shaft, if the outer diameter is twice of inside diameter, assuming that the maximum torque is 20% greater than the mean torque.
2. Two 400 mm diameter pulleys are keyed to a simply supported shaft 500 mm apart. Each pulley is 100 mm from its support and has horizontal belts, tension ratio being 2.5. If the shear stress is to be limited to 80 MPa while transmitting 45 kW at 900 r.p.m., find the shaft diameter if it is to be used for the input-output belts being on the same or opposite sides.
3. Fig. shows a shaft from a hand-operated machine. The frictional torque in the journal bearings at  $A$  and  $B$  is 15 N-m each. Find the diameter ( $d$ ) of the shaft (on which the pulley is mounted) using maximum distortion energy criterion. The shaft

material is 40 C 8 steel for which the yield stress in tension is 380 MPa and the factor of safety is 1.5.

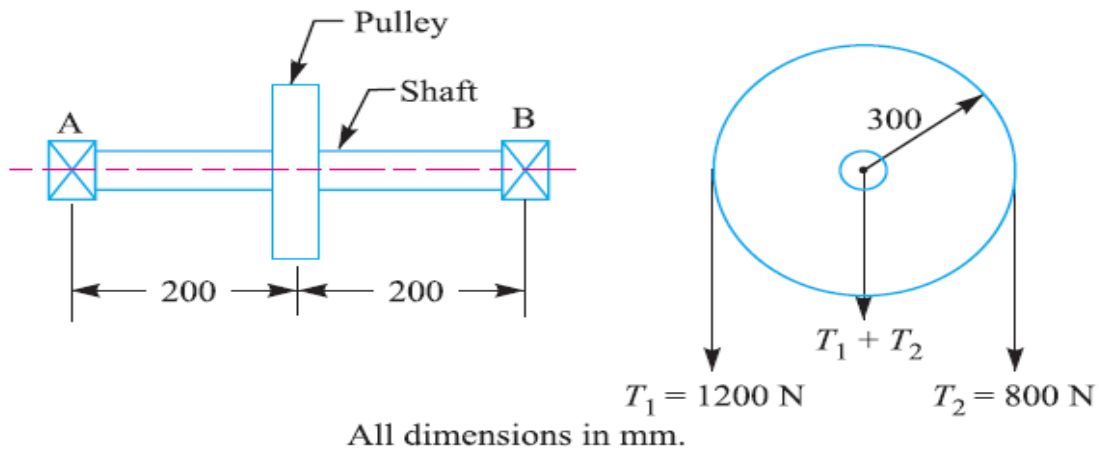

4. A shaft made of steel receives 7.5 kW power at 1500 r.p.m. A pulley mounted on the shaft as shown in Fig. 14.19 has ratio of belt tensions 4. The gear forces are as follows:  $F_t = 1590$  N;  $F_r = 580$  N. Design the shaft diameter by maximum shear stress theory. The shaft material has the following properties: Ultimate tensile strength = 720 MPa; Yield strength = 380 MPa; Factor of safety = 1.5.

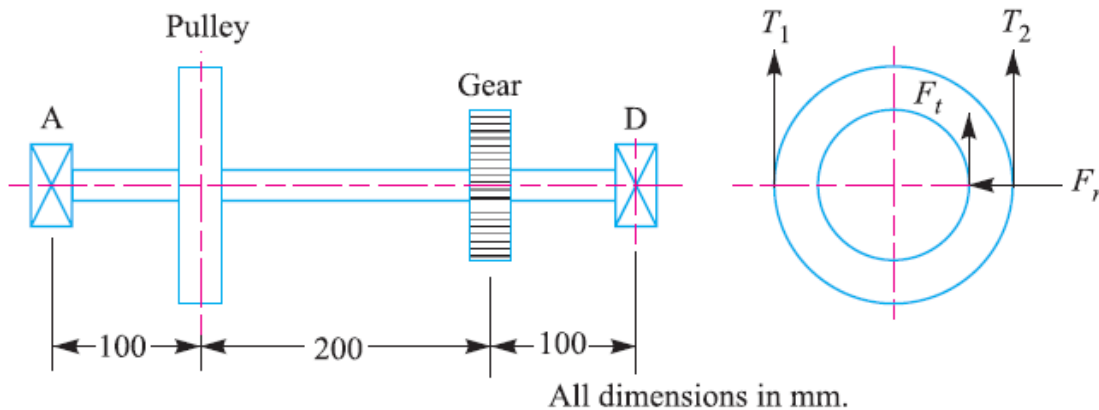

5. The internal diameter of a hollow shaft is  $\frac{2}{3}$  rd of its external diameter. Compare the strength and stiffness of the shaft with that of a solid shaft of the same material.

6. The shaft of an axial flow rotary compressor is subjected to a maximum torque of 2000 N-m and a maximum bending moment of 4000 N-m. The combined shock and fatigue factor in torsion is 1.5 and that in bending is 2. Design the diameter of

the shaft, if the shear stress in the shaft is 50 MPa. Design a hollow shaft for the above compressor taking the ratio of outer diameter to the inner diameter as 2. What is the percentage saving in material ? Also compare the stiffness.

7. A steel shaft has a diameter of 25 mm. The shaft rotates at a speed of 600 r.p.m. and transmits 30 kW through a gear. The tensile and yield strength of the material of shaft are 650 MPa and 353 MPa respectively. Taking a factor of safety 3, select a suitable key for the gear. Assume that the key and shaft are made of the same material.

8. Design a cast iron protective flange coupling to connect two shafts in order to transmit 7.5 kW at 720 r.p.m. The following permissible stresses may be used :

Permissible shear stress for shaft, bolt and key material = 33 MPa

Permissible crushing stress for bolt and key material = 60 MPa

Permissible shear stress for the cast iron = 15 MPa

9. Two shafts made of plain carbon steel are connected by a rigid protective type flange coupling. The shafts are running at 500 r.p.m. and transmit 25 kW power. Design the coupling completely for overload capacity 25 per cent in excess of mean transmitted torque capacity. Assume the following permissible stresses for the coupling components :

Shaft Permissible tensile stress = 60 MPa; Permissible shear stress = 35 MPa

Keys Rectangular formed end sunk key having permissible compressive strength = 60 MPa

Bolts are Six numbers made of steel having permissible shear stress = 28 MPa

Flanges of Cast iron having permissible shear stress = 12 MPa

Draw two views of the coupling you have designed.

10. A flanged protective type coupling is required to transmit 50 kW at 2000 r.p.m. Find: (a) Shaft diameters if the driving shaft is hollow with  $d_i/d_o = 0.6$  and driven shaft is a solid shaft. Take  $\tau = 100$  MPa. (b) Diameter of bolts, if the coupling uses four bolts. Take  $\sigma_c = \sigma_t = 70$  MPa and  $\tau = 25$  MPa. Assume pitch circle diameter as about 3 times the outside diameter of the hollow shaft.

(c) Thickness of the flange and diameter of the hub. Assume  $\sigma_c = 100$  MPa and  $\tau = 125$  MPa. (d) Make a neat free hand sketch of the assembled coupling showing a longitudinal sectional elevation with the main dimensions. The other dimensions may be assumed suitably.



**UNIT –III TEMPORARY AND PERMANENT JOINTS**  
**PART-A**

1. What do you understand by the single start and double start threads?
2. Discuss on bolts of uniform strength giving examples of practical applications of such bolts.
3. State three conditions where tap bolts are used.
4. What are the different stresses setups in a bolt due to initial tightening?
5. What is threaded joint?
6. What is a stud?
7. How is a bolt designated? Give examples.
8. How do you design a bolt with uniform strength?
9. What is the meaning of bolt M24 x 2?
10. What is purpose of cotter joint?
11. Which type of thread would you suggest for the following?
  - a. Lead screw for a lathe
  - b. Fastening of a bracket to a wall
  - c. Screw jack.
12. What are the reasons of replacing riveted joint by welded joint in modern equipment?
13. Why reinforcement is normally required in welded joints?
14. What are the advantages of welded joints compared with riveted joints?
15. Write down the expression for strength of parallel fillet weld in terms of permissible shear stress, leg of weld and length of welded joint.
16. What is the minimum size for fillet weld? If required weld size from strength consideration is too small how will you fulfill the condition of minimum weld size?
17. Name the possible modes of failure of riveted joint.
18. What do you mean by efficiency of a riveted joint? The efficiency of a riveted joint is always less than 100% give your comment.
19. Distinguish between cotter joint and knuckle joint.
20. What is a cotter joint? Explain with the help of a neat sketch, how a cotter joint is made?

**PART-B**

1. A pulley bracket, as shown in Fig., is supported by 4 bolts, two at *A-A* and two at *B-B*. Determine the size of bolts using an allowable shear stress of 25 MPa for the material of the bolts.

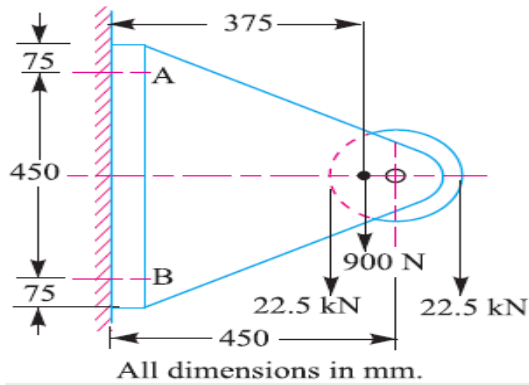

2. A wall bracket, as shown in Fig., is fixed to a wall by means of four bolts. Find the size of the bolts and the width of bracket. The safe stress in tension for the bolt and bracket may be assumed as 70 MPa.

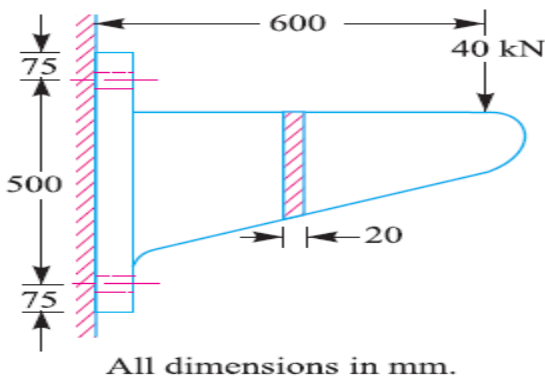

3. A bracket is bolted to a column by 6 bolts of equal size as shown in Fig. 11.51. It carries a load of 50 kN at a distance of 150 mm from the centre of column. If the maximum stress in the bolts is to be limited to 150 MPa, determine the diameter of bolt.

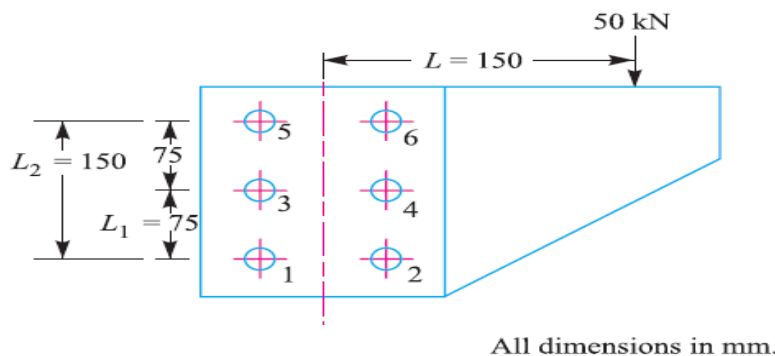

4. A bracket, as shown in Fig. is fixed to a vertical steel column by means of five standard bolts. Determine : (a) The diameter of the fixing bolts, and (b) The thickness of the arm of the bracket. Assume safe working stresses of 70 MPa in tension and 50 MPa in shear.

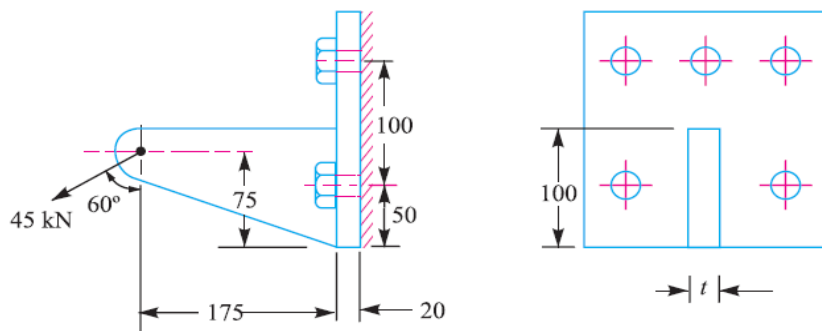

All dimensions in mm.

5. Design a cotter joint to connect two mild steel rods for a pull of 30 kN. The maximum permissible stresses are 55 MPa in tension; 40 MPa in shear and 70 MPa in crushing. Draw a neat sketch of the joint designed.
6. Design a knuckle joint to connect two mild steel bars under a tensile load of 25 kN. The allowable stresses are 65 MPa in tension, 50 MPa in shear and 83 MPa in crushing.
7. A bracket is riveted to a column by 6 rivets of equal size as shown in Fig. 9.38. It carries a load of 100 kN at a distance of 250 mm from the column. If the maximum shear stress in the rivet is limited to 63 MPa, find the diameter of the rivet .

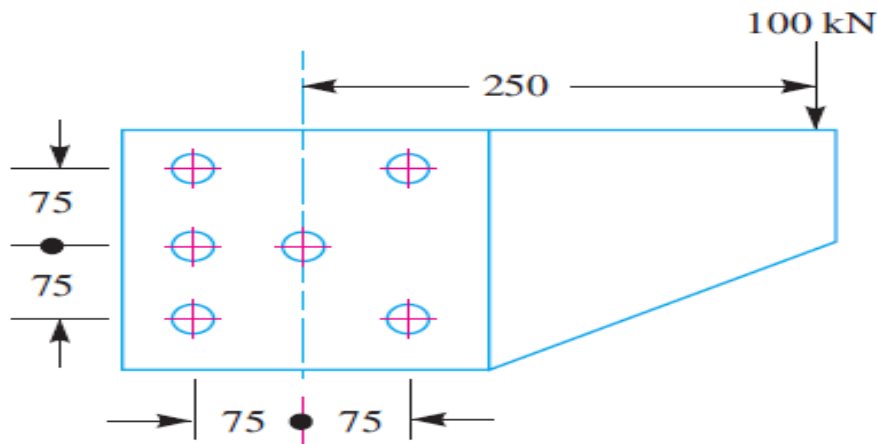

All dimensions in mm.

8. A bracket is welded to the side of a column and carries a vertical load  $P$ , as shown in Fig. 10.38. Evaluate  $P$  so that the maximum shear stress in the 10 mm fillet welds is 80 MPa.

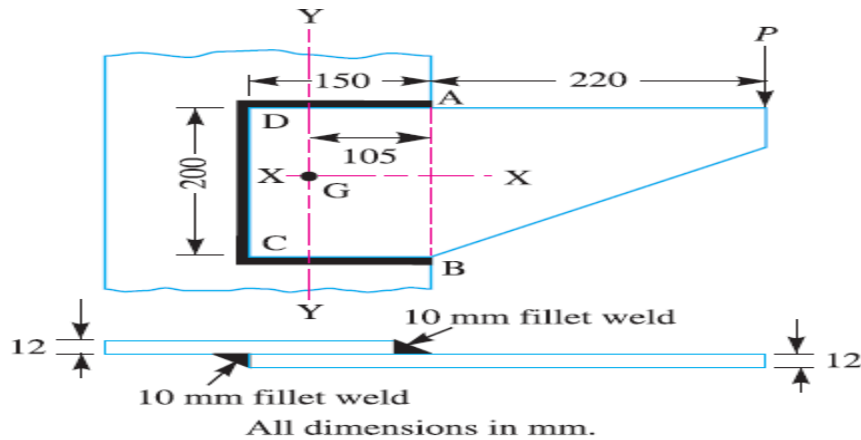

9. A bracket, as shown in Fig. 10.39, carries a load of 40 kN. Calculate the size of weld, if the allowable shear stress is not to exceed 80 MPa.

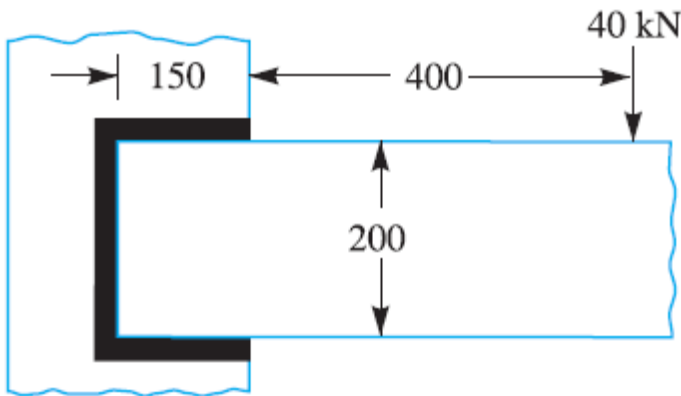

All dimensions in mm.

\*\*\*\*\*

### Unit-IV ENERGY STORING ELEMENTS AND ENGINE COMPONENTS PART-A

1. What is the function of a spring? In which type of spring the behaviour is non-linear?
2. Discuss the materials and practical applications for the various types of springs.
3. The extension springs are in considerably less use than the compression springs. Why?
4. Explain one method of avoiding the tendency of a compression spring to buckle.
5. What do you understand by full length and graduated leaves of a leaf spring? Write the expression for determining the stress and deflection in full length and graduated leaves.
6. What is nipping in a leaf spring? Discuss its role. List the materials commonly used for the manufacture of the leaf springs.

7. What is the effect of increase in wire diameter on the allowable stress value?
8. What are constant widths and constant strength springs?
9. What is meant by coefficient of fluctuation of energy with reference to flywheels?
10. What are the applications of concentric spring?
11. Two springs of stiffness  $K_1$  and  $K_2$  are connected in series. What is the stiffness of connection?
12. What are the different styles of end for helical compression spring?
13. When two concentric springs of stiffness 100 N/mm and 50 N/mm respectively are subjected to an axial load of 750 N, what will be the deflection of each spring?
14. How do you eliminate the surge in springs?
15. What is purpose of leaf spring that is used in automobiles?
16. What type of stresses is produced in a disc flywheel?
17. What is the main function of a flywheel in an engine?
18. In what way does a flywheel differ from that of a governor? Illustrate your answer with suitable examples.
19. Define 'coefficient of fluctuation of speed' and 'coefficient of steadiness'.
20. Discuss the various types of stresses induced in a flywheel rim.
21. Why is piston end of a connecting rod kept smaller than the crank pin end?
22. Explain the various stresses induced in the connecting rod.
23. Under what force, the big end bolts and caps are designed?
24. Explain the various types of crankshafts.
25. At what angle of the crank, the twisting moment is maximum in the crankshaft?
26. What are the methods and materials used in the manufacture of crankshafts

#### **PART-B**

1. Design a compression helical spring to carry a load of 500 N with a deflection of 25 mm. The spring index may be taken as 8. Assume the following values for the spring material: Permissible shear stress = 350 MPa  
Modulus of rigidity = 84 kN/mm<sup>2</sup>

$$\text{Wahl's factor} = \frac{4C - 1}{4C - 4} + \frac{0.615}{C}, \text{ where } C = \text{spring index.}$$

2. Design a helical spring for a spring loaded safety valve for the following conditions: Operating pressure = 1 N/mm<sup>2</sup>  
Maximum pressure when the valve blows off freely = 1.075 N/mm<sup>2</sup>  
Maximum lift of the valve when the pressure is 1.075 N/mm<sup>2</sup> = 6 mm  
Diameter of valve seat = 100 mm  
Maximum shear stress = 400 MPa

Modulus of rigidity = 86 kN/mm<sup>2</sup>

Spring index = 5.5

3. A vertical spring loaded valve is required for a compressed air receiver. The valve is to start opening at a pressure of 1 N/mm<sup>2</sup> gauge and must be fully open with a lift of 4 mm at a pressure of 1.2 N/mm<sup>2</sup> gauge. The diameter of the port is 25 mm. Assume the allowable shear stress in steel as 480 MPa and shear modulus as 80 kN/mm<sup>2</sup>. Design a suitable close coiled round section helical spring having squared ground ends. Also specify initial compression and free length of the spring.

4. A railway wagon weighing 50 kN and moving with a speed of 8 km per hour has to be stopped by four buffer springs in which the maximum compression allowed is 220 mm. Find the number of turns in each spring of mean diameter 150 mm. The diameter of spring wire is 25 mm. Take  $G = 84 \text{ kN/mm}^2$ .

5. A semi-elliptical spring has ten leaves in all, with the two full length leaves extending 625 mm. It is 62.5 mm wide and 6.25 mm thick. Design a helical spring with mean diameter of coil 100 mm which will have approximately the same induced stress and deflection for any load. The Young's modulus for the material of the semi-elliptical spring may be taken as 200 kN/mm<sup>2</sup> and modulus of rigidity for the material of helical spring is 80 kN/mm<sup>2</sup>.

6. Design a leaf spring for the following specifications : Total load = 140 kN ; Number of springs supporting the load = 4 ; Maximum number of leaves = 10; Span of the spring = 1000 mm ; Permissible deflection = 80 mm. Take Young's modulus,  $E = 200 \text{ kN/mm}^2$  and allowable stress in spring material as 600 MPa.

7. Design a cast iron flywheel for a four stroke cycle engine to develop 110 kW at 150 r.p.m. The work done in the power stroke is 1.3 times the average work done during the whole cycle. Take the mean diameter of the flywheel as 3 metres. The total fluctuation of speed is limited to 5 per cent of the mean speed. The material density is 7250 kg / m<sup>3</sup>. The permissible shear stress for the shaft material is 40 MPa and flexural stress for the arms of the flywheel is 20 MPa.

8. A punching press is required to punch 40 mm diameter holes in a plate of 15 mm thickness at the rate of 30 holes per minute. It requires 6 N-m of energy per mm<sup>2</sup> of sheared area. Determine the moment of inertia of the flywheel if the punching takes one-tenth of a second and the r.p.m. of the flywheel varies from 160 to 140.

9. Design completely the flywheel, shaft and the key for securing the flywheel to the shaft, for a punching machine having a capacity of producing 30 holes of 20 mm diameter per minute in steel plate 16 mm thickness. The ultimate shear stress for the material of the plate is 360 MPa. The actual punching operation estimated to last for a period of  $36^\circ$  rotation of the punching machine crankshaft. This crank shaft is powered by a flywheel shaft through a reduction gearing having a ratio

1 :8. Assume that the mechanical efficiency of the punching machine is 80% and during the actual punching operation the flywheel speed is reduced by a maximum of 10%. The diameter of flywheel is restricted to 0.75 m due to space limitations.

10. Determine the dimensions of an *I*-section connecting rod for a petrol engine from the following data: Diameter of the piston = 110 mm; Mass of the reciprocating parts = 2 kg; Length of the connecting rod from centre to centre = 325 mm; Stroke length = 150 mm; R.P.M. = 1500 with possible over speed of 2500; Compression ratio = 4: 1; Maximum explosion pressure = 2.5 N/mm<sup>2</sup>.

11. A connecting rod is required to be designed for a high speed, four stroke I.C. engine. The following data are available. Diameter of piston = 88 mm; Mass of reciprocating parts = 1.6 kg; Length of connecting rod (centre to centre) = 300 mm; Stroke = 125 mm; R.P.M. = 2200 (when developing 50 kW); Possible over speed = 3000 r.p.m.; Compression ratio = 6.8: 1 (approximately); Probable maximum explosion pressure (assumed shortly after dead centre, say at about  $3^\circ$ ) = 3.5 N/mm<sup>2</sup>. Draw fully dimensioned drawings of the connecting rod showing the provision for the lubrication.

.....

### Unit-V BEARINGS PART-A

1. What are journal bearings? Give a classification of these bearings.
2. What is meant by hydrodynamic lubrication?
3. Explain wedge film and squeeze film journal bearings.
4. List the important physical characteristics of a good bearing material.
5. What is the procedure followed in designing a journal bearing?
6. For a journal bearing the maximum operating temperature must be less than 80°C. Why?
7. State the merits of hydrostatic bearings.
8. What is a quill bearing?
9. State the disadvantages of trust ball bearing.

10. List any four advantages of rolling contact bearings over sliding contact bearings.
11. What is meant by life of anti-friction bearings?
12. Differentiate the rated life of bearing with its average life.
13. What is the advantage of Teflon which is used for bearings?
14. Name the material that is used for to make ball bearings.

### **PART-B**

1. The ball bearings are to be selected for an application in which the radial load is 2000N during 90 per cent of the time and 8000 N during the remaining 10 per cent. The shaft is to rotate at 150 r.p.m. Determine the minimum value of the basic dynamic load rating for 5000 hours of operation with not more than 10 per cent failures.
2. A single row deep groove ball bearing operating at 2000 r.p.m. is acted by a 10 kN radial load and 8 kN thrust load. The bearing is subjected to a light shock load and the outer ring is rotating. Determine the rating life of the bearing.
3. A ball bearing subjected to a radial load of 4000 N is expected to have a satisfactory life of 12 000 hours at 720 r.p.m. with a reliability of 95%. Calculate the dynamic load carrying capacity of the bearing, so that it can be selected from manufacturer's catalogue based on 90% reliability. If there are four such bearings each with a reliability of 95% in a system, what is the reliability of the complete system?
4. A rolling contact bearing is subjected to the following work cycle : (a) Radial load of 6000 N at 150 r.p.m. for 25% of the time; (b) Radial load of 7500 N at 600 r.p.m. for 20% of the time; and (c) Radial load of 2000 N at 300 r.p.m. for 55% of the time. The inner ring rotates and loads are steady. Select a bearing for an expected average life of 2500 hours.
5. A journal bearing is proposed for a steam engine. The load on the journal is 3 kN, diameter 50 mm, length 75 mm, speed 1600 r.p.m., diametral clearance 0.001 mm, ambient temperature 15.5°C. Oil SAE 10 is used and the film temperature is 60°C. Determine the heat generated and heat dissipated. Take absolute viscosity of SAE10 at 60°C = 0.014 kg/m-s.
6. A journal bearing is to be designed for a centrifugal pump for the following data : Load on the journal = 12 kN ; Diameter of the journal = 75 mm ; Speed = 1440



r.p.m ; Atmospheric temperature of the oil =  $16^{\circ}\text{C}$  ; Operating temperature of the oil =  $60^{\circ}\text{C}$ ; Absolute viscosity of oil at  $60^{\circ}\text{C}$  =  $0.023 \text{ kg/m-s}$ . Give a systematic design of the bearing.

7. Design a journal bearing for a centrifugal pump running at 1440 r.p.m. The diameter of the journal is 100 mm and load on each bearing is 20 kN. The factor  $ZN/p$  may be taken as 28 for centrifugal pump bearings. The bearing is running at  $75^{\circ}\text{C}$  temperature and the atmosphere temperature is  $30^{\circ}\text{C}$ . The energy dissipation coefficient is  $875 \text{ W/m}^2/^{\circ}\text{C}$ . Take diametral clearance as 0.1 mm.

8. A journal bearing with a diameter of 200 mm and length 150 mm carries a load of 20 kN, when the journal speed is 150 r.p.m. The diametral clearance ratio is 0.0015. If possible, the bearing is to operate at  $35^{\circ}\text{C}$  ambient temperature without external cooling with a maximum oil temperature of  $90^{\circ}\text{C}$ . If external cooling is required, it is to be as little as possible to minimise the required oil flow rate and heat exchanger size.

1. What type of oil do you recommend?
2. Will the bearing operate without external cooling?
3. If the bearing operates without external cooling, determine the operating oil temperature?
4. If the bearing operates with external cooling, determine the amount of oil in kg/min required to carry away the excess heat generated over heat dissipated, when the oil temperature rises from  $85^{\circ}\text{C}$  to  $90^{\circ}\text{C}$ , when passing through the bearing.

\*\*\*\*\*